

Balancing Equations Challenge

Part A: Parts & Pieces

- (1) Circle each subscript in each chemical formula.
- (2) Draw a square around each coefficient.
- (3) Answer the questions related to each chemical formula.



What element does the O represent?

How many atoms of each element
are in the formula shown?
C = _____ O = _____

How many atoms of Hydrogen are
in this formula as shown?



How many atoms each element
are in the formula shown?
C = _____ H = _____

How many atoms each element
are in the formula shown?
Na = _____ S = _____ O = _____

Part B: Label the chemical equation using PRODUCT, REACTANTS, SUBSCRIPT, COEFFICIENT, and YIELDS.

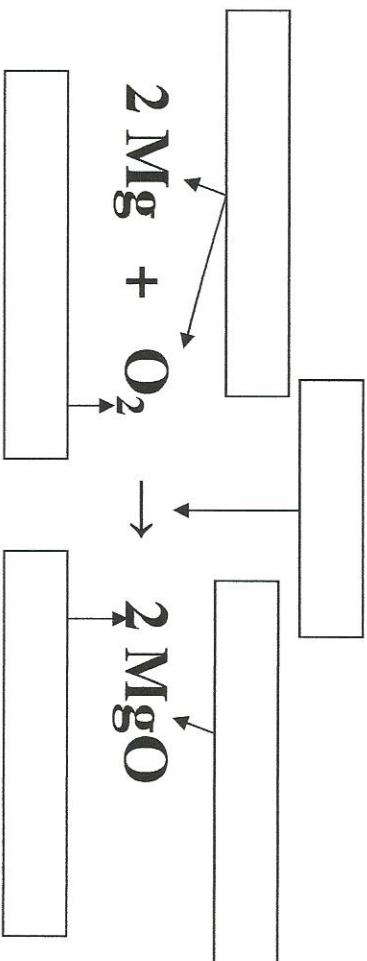

Part C: Balance each of the following equations.

Remember → List the atoms, count, and solve!

